

## Section 4: WHAT MAKES CHARGE MOVE IN A CIRCUIT?

### INTRODUCTION

“Why does capacitor charging stop, even though a battery is still trying to make charge move?”

“What makes charge move during discharging, even though there is no battery to cause movement?”

These questions will be investigated in this section.

### INVESTIGATION ONE: WHAT HAPPENS WHILE A CAPACITOR CHARGES?

#### 4.1 Demonstration: Experimenting with an already-charged capacitor

Your teacher will do a demonstration using a  $0.025 \mu\text{F}$  capacitor, two long bulbs, and several three-cell battery packs. We will also use a compass to monitor the direction of charge flow. Initially, the circuit will be set up to look like Figure 4.1a. You can see the compass, located just above the top capacitor plate.

1. At the instant the connection was made, what happened to the bulbs?
2. Based on your observations, decide if you should draw starbursts on the bulbs in Fig. 4.1a. Then, ACT on that decision. (Or not).
3. At the instant the connection was made, what happened to the compass?
4. Represent your answer to Q3 by drawing a needle on the compass in Fig. 4.1a.

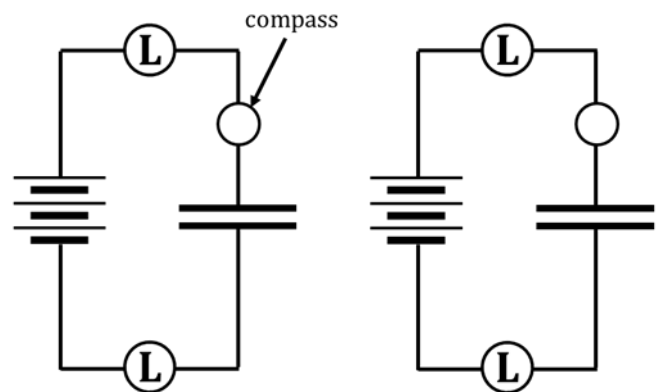

**Fig. 4.1a**  
charging; first  
instant of connection

**Fig. 4.1b**  
charging completed

5. Also, draw a NEARLY-CONTINUOUS ARROW in Fig. 4.1a to show the direction of conventional charge flow during charging. Also, draw ARROWTAILS next to each bulb to indicate flow rate.
6. Now, look at Fig. 4.1b; NOTE the figure's description. Decide IF and HOW you should draw starbursts, arrowtails, a compass needle, and/or a flow arrow in Fig. 4.1b. Then DO it.

We won't always be doing this next step, but it serves a useful purpose here...

7. In Fig. 4.1b, to show that the capacitor is now charged using three batteries, DRAW three small + signs near the plate that has gained charge due to the action of the three batteries. ALSO, draw three small - signs near the plate that has lost charge due to the action of the three batteries.

Now look at Fig. 4.1c. We will soon be adding in a second three-battery pack to “help” the first battery pack. We will NOT have discharged the capacitor from Fig. 4.1b.

8. Before we add the second battery pack, hypothesize. Circle your predictions.

- |   |                      |                    |                           |
|---|----------------------|--------------------|---------------------------|
| i. Will the bulbs light up?   | YES                  | NO                 |                           |
| ii. Skip this question if you answered NO above. If you answered YES, then... |                      |                    |                           |
| How will the initial brightness compare to before?                            | BRIGHTER THAN BEFORE | DIMMER THAN BEFORE | SAME BRIGHTNESS AS BEFORE |
| iii. Will the compass deflect?  | YES                  | NO                 |                           |
| iv. Skip this question if you answered NO above. If you answered YES, then... |                      |                    |                           |
| HOW MUCH will the compass deflect, compared to before?                        | MORE THAN BEFORE     | LESS THAN BEFORE   | SAME AMOUNT AS BEFORE     |
| What will be the DIRECTION of the compass deflection?                         | SAME AS BEFORE       | OPPOSITE TO BEFORE |                           |

Your teacher will now complete the circuit with the second battery pack.

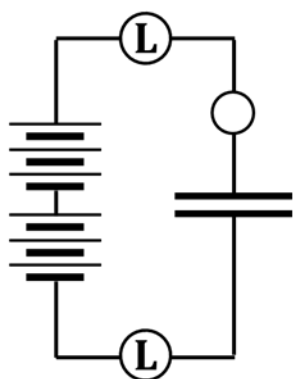

**Fig. 4.1c**  
charging; first instant of connection

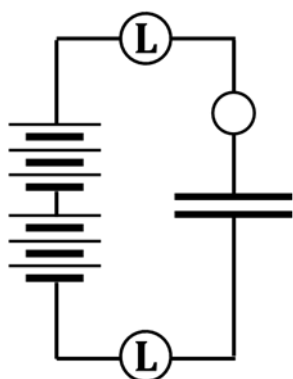

**Fig. 4.1d**  
charging completed

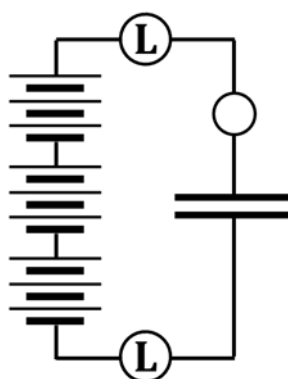

**Fig. 4.1e**  
charging; first instant of connection

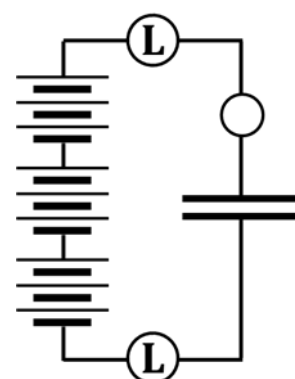

**Fig. 4.1f**  
charging completed

9. Did the bulbs light? If they did, how did their initial brightness compare to before? Did the compass deflect? If it did, how did the direction and amount compare to before? Was there any evidence that additional charge was moved from, or onto, the plates? ANSWER THESE QUESTIONS BY DRAWING (or not) the following things into Fig. 4.1c: starbursts, a compass needle, a nearly-continuous arrow, arrowtails, and/or + and - signs. Remember that these markings need to represent the state of affairs as labeled in Fig. 4.1c; namely, at the FIRST INSTANT of connection.

10. Now, draw appropriate markings, as needed (or not), into Fig. 4.1d:

starbursts, arrowtails, compass needle, flow direction arrow, and/or + and - signs.

Okay, we’re going to do this one more time, by adding a THIRD three-cell battery pack, as depicted in Fig. 4.1e. Again, we will NOT discharge the capacitor before we add the third set of batteries.

11. Before we add the third battery pack, hypothesize. Circle your predictions.

- |   |                      |                    |                           |
|---|----------------------|--------------------|---------------------------|
| i. Will the bulbs light up?   | YES                  | NO                 |                           |
| ii. Skip this question if you answered NO above. If you answered YES, then... |                      |                    |                           |
| How will the initial brightness compare to before?                            | BRIGHTER THAN BEFORE | DIMMER THAN BEFORE | SAME BRIGHTNESS AS BEFORE |
| iii. Will the compass deflect?  | YES                  | NO                 |                           |
| iv. Skip this question if you answered NO above. If you answered YES, then... |                      |                    |                           |
| HOW MUCH will the compass deflect, compared to before?                        | MORE THAN BEFORE     | LESS THAN BEFORE   | SAME AMOUNT AS BEFORE     |
| What will be the DIRECTION of the compass deflection?                         | SAME AS BEFORE       | OPPOSITE TO BEFORE |                           |

Your teacher will now complete the circuit with the third battery pack.

12. Did the bulbs light? If they did, how did their initial brightness compare to before? Did the compass deflect? If it did, how did the direction and amount compare to before? Was there any evidence that additional charge was moved from, or onto, the plates? ANSWER THESE QUESTIONS BY DRAWING (or not) the following things into Fig. 4.1e: starbursts, a compass needle, a nearly-continuous arrow, arrowtails, and/or + and - signs. Remember that these markings need to represent the state of affairs as labeled in Fig. 4.1e; namely, at the first instant of connection.

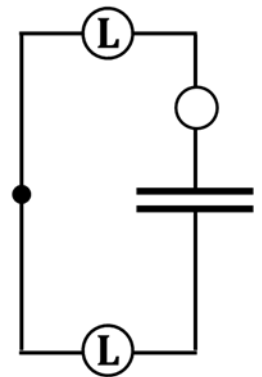

**Fig. 4.1g**  
capacitor discharging

13. Draw markings, as needed (or not), into Fig. 4.1f, ON THE PREVIOUS PAGE: starbursts, compass needle, arrowtails, flow direction arrow, and/or + and - signs.

In just a minute, your teacher will remove ALL of the battery packs from the circuit and connect the free ends of the wire, as shown in Fig. 4.1g. As you know, this will result in the discharge of the capacitor.

14. Before we do that, hypothesize. Circle your predictions about what will happen.

- |   |                      |                    |                           |
|---|----------------------|--------------------|---------------------------|
| i. Will the bulbs light up?   | YES                  | NO                 |                           |
| ii. Skip this question if you answered NO above. If you answered YES, then... |                      |                    |                           |
| How will the initial brightness compare to before?                            | BRIGHTER THAN BEFORE | DIMMER THAN BEFORE | SAME BRIGHTNESS AS BEFORE |
| iii. Will the compass deflect?  | YES                  | NO                 |                           |
| iv. Skip this question if you answered NO above. If you answered YES, then... |                      |                    |                           |
| HOW MUCH will the compass deflect, compared to before?                        | MORE THAN BEFORE     | LESS THAN BEFORE   | SAME AMOUNT AS BEFORE     |
| What will be the DIRECTION of the compass deflection?                         | SAME AS BEFORE       | OPPOSITE TO BEFORE |                           |

15. After your teacher discharges the capacitor, draw markings as needed (or not), into Fig. 4.1g: starbursts, compass needle, arrowtails, flow direction arrow, and/or + and – signs.
16. What number of batteries was the capacitor “pushing like” in each figure? Also, list bulb brightness.

**Bulbs: How Bright?**

<b>Fig. 4.1a:</b>	3 batteries vs. a “__-battery” capacitor	_____
<b>Fig. 4.1b:</b>	3 batteries vs. a “__-battery” capacitor	_____
<b>Fig. 4.1c:</b>	6 batteries vs. a “__-battery” capacitor	_____
<b>Fig. 4.1d:</b>	6 batteries vs. a “__-battery” capacitor	_____
<b>Fig. 4.1e:</b>	9 batteries vs. a “__-battery” capacitor	_____
<b>Fig. 4.1f:</b>	9 batteries vs. a “__-battery” capacitor	_____
<b>Fig. 4.1g:</b>	a “__-battery capacitor” vs. NOTHING	_____

17. Think back now on what happened when we charged the capacitor, first with three batteries, then with six, and finally with nine. In each case, the compass eventually stopped deflecting and the bulbs stopped lighting. You could have stated with certainty WAY BACK IN SECTION 1 of this CASTLE program that the compass stopped deflecting and the bulbs stopped lighting because, in the circuit...
18. And, why, would you guess THAT happened? Look back at your answers to Q16 above and come up with something reasonable. Your answer should mention the terms *batteries*, *capacitor*, *equal*, and *different*. If you know what the word “oomph” means, you could use that as well.

**4.2 Commentary: Compression, concentration, and the electric pressure idea**



When you pump air into a bicycle tire, you increase the concentration of air in the tire by adding more air to a given volume. The result, as you know, is that the pressure of the air inside the tire will increase. And, the higher the pressure goes, the more the air “wants” to escape from the tire, either out the same hole it came in OR out through another hole in the tire! Also – perhaps you’ve noticed – the more air you put into a tire, the tougher it gets to put MORE in. When you start pumping up a tire, it’s usually pretty easy; soon,

however, you notice that you are getting tired (pun intended). And you are getting tired (pun intended) for two reasons: (1) you’ve been pushing air for a while and your muscles are fatigued, and (2) it literally gets more and more difficult to push additional air into the tire.

There are close similarities between extra CHARGE being pumped onto a capacitor plate (by a battery) and extra AIR being pumped into a tire (by, maybe, YOU). As extra charge flows onto a plate, the concentration of charge on the plate increases. You can imagine the charge on the plate being COMPRESSED as more and more charge is added, like air in the tire being COMPRESSED as more and more air is added.

We mentioned above that AIR compressed into a tire will try to expand BACK, maybe out the hole it came in through. Similarly, CHARGE compressed onto a capacitor plate will try to expand BACK out of the plate through a wire, maybe the wire it came in through. Here are two things we should observe if, in fact, compressed charge behaves the same way as compressed air:

- (1) Increasingly-strong “back pressure” or “reverse-pushing” by increasingly-compressed charge should make it tougher and tougher for the battery to pump yet more charge onto the top capacitor plate.

That fact should result in the bulbs getting progressively dimmer while the capacitor continues to charge. At some point, the charges will be SO compressed on the top plate that the battery cannot push ANY additional charge onto the plate. It's like your bicycle tire being SO full of air that you aren't physically strong enough to push the pump handle down any longer.

- (2) When the battery is removed, the compression in the top (i.e., the +) plate will push charge back, in the reverse direction; the capacitor is discharging. As decompression continues, the reverse-pushing will weaken, making the bulbs dimmer until, when there is neither a forward nor a reverse push, the bulbs go out.

The two bulb-dimming descriptions just described are, in fact, observed. These observations provide strong evidence that compressed charge in circuits REALLY DOES behave like compressed air.



Air pressure is the name given to the tendency for compressed AIR to expand. Electric pressure is the name given to the tendency for compressed CHARGE to expand. Electric pressure is known in electrical terms as voltage and is measured in the unit volts (V). The volt is named in honor of the Italian scientist who, in 1778, first introduced the concept of electric pressure: Alessandro Giuseppe Antonio Anastasio Volta. (I'm guessing his parents just called him Al.)

### 4.3 Commentary: Is the air analogy really right?

Thinking about electric pressure as being similar to air pressure helps you keep in mind that charge – like air – always tries to move from a place of higher pressure to a place of lower pressure. It reminds you that the movement will continue until the pressures are equalized. The same idea that helps you understand when and where AIR moves will also help you predict when and where CHARGE will move.

However, we shouldn't necessarily expect charge to behave like air in absolutely every respect. We will use the term ELECTRIC PRESSURE to emphasize that compressed charge behaves like compressed air in many important respects, but there are also other respects – which we don't need to concern ourselves with, at this point – in which air and charge behave very differently.

### 4.4 Exercise: How does a battery establish high and low pressures?

In terms of electric pressure, a battery has one terminal – the (+) one – with HIGH electric pressure and one terminal – the (-) one – with LOW electric pressure.



1. Keeping in mind the compression-and-pressure discussion of Section 4.2, you would guess that the terminal where mobile charges are VERY COMPRESSED (i.e., crowded together) is the \_\_\_ terminal. Similarly, you would guess that the terminal where mobile charges are NOT very compressed (i.e., quite spread out) is the \_\_\_ terminal.
2. Therefore, INSIDE the battery, SOMETHING must happen that moves mobile charge (WITHIN the battery) AWAY FROM the \_\_\_ terminal and TOWARD the \_\_\_ terminal.
3. The SOMETHING that happens is what your high school chemistry class was all about. What WAS your high school chemistry class all about? I'll give you a hint: It was all about the THINGS that are modeled every time we write a chemical equation, with reactants on the left side and products on the right. WHAT real-life events are modeled by written-out chemical equations?

4. Summarize your answers to Q1-3 by completing this:
  - a. In Fig. 4.4, label the ends of the battery with (+) or (-).
  - b. Write this...CCCCCCCCCCCC...along the terminal with a HIGH elec. pressure and write this... C C C ... along the terminal with a LOW elec. pressure. This shows the charges (C) very densely packed at the high-pressure end and NOT densely packed at the low-pressure end.
  - c. Read what's typed inside the battery and fill in what's missing.

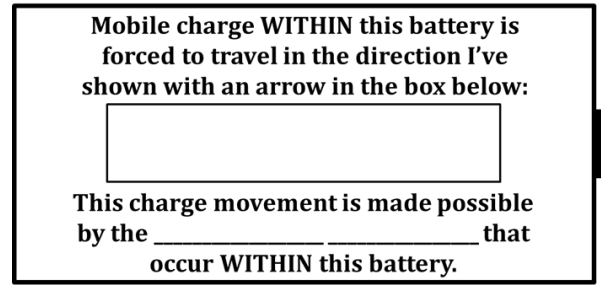

**Fig. 4.4**

#### 4.5 Exercise: The air capacitor, viewed through the lens of pressure

Figure 4.5a shows an air capacitor, which we met for the first time back in Section 3. Recall that an air capacitor has two chambers of air separated by a flexible, balloon membrane. The two chambers can exchange air with the environment through the open tubes on their ends. NOTE that, in Fig. 4.5a and others, the balloon is not shown; this is because you will be drawing the membrane into those figures.

1. The air capacitor shown in Fig. 4.5a is open to the atmosphere on both sides, via the glass tubes. The air pressure in each chamber is thus the same as the atmospheric pressure. We will call this pressure **NORMAL PRESSURE**. DRAW a vertical membrane in the center of Fig. 4.5a to show that the balloon isn't deflected, and write "NORMAL PRES." in each chamber of Fig. 4.5a.
2. In Fig. 4.5b, imagine **EXHALING** into the leftmost tube. First, show how the balloon would deflect. The pressure on the left will increase due to the exhalation, so write "HIGH PRES." on the left chamber. The right side remains open to the atmosphere, so write "NORMAL PRES." there.
3. In Fig. 4.5c, imagine **INHALING** through the leftmost tube. Show how the balloon would deflect. The pressure on the left will drop due to the inhalation, so write "LOW PRES." there. Correctly label the rightmost chamber's pressure, too.
4. In Fig. 4.5d, Person A **EXHALES** into the left chamber; Person B **INHALES** into the right. Fill in Fig. 4.5d.
5. In Fig. 4.5e, Person A **EXHALES** into the left side; Person B **EXHALES** equally into the right. Fill in Fig. 4.5e.
6. In Fig. 4.5f, Person A **INHALES** from the left; Person B **INHALES** equally from the right. Fill in Fig. 4.5f.



**Fig. 4.5a**



**Fig. 4.5b**



**Fig. 4.5c**



**Fig. 4.5d**



**Fig. 4.5e**



**Fig. 4.5f**

7. Of the six figures above (4.5a-4.5f), how many of them result in NO movement of the balloon? \_\_\_\_  
Also, write down here any of the figure numbers that apply to this question.
8. Look again at the figures you listed in your answer to Q7. In terms of balloon deflection, is there ANY difference in the OBSERVABLE results of any of those figures? If there is, list here the observable difference(s), otherwise just write "NO" and move on.
9. Of the six figures above, how many of them result in a MEDIUM AMOUNT of balloon movement? \_\_\_\_  
Also, write down here any of the figure numbers that apply to this question.
10. Look again at the figures you listed in your answer to Q9. In terms of balloon deflection, is there ANY difference in the OBSERVABLE results of any of those figures? If there is, list here the observable difference(s), otherwise just write "NO" and move on.
11. Of the six figures above, how many of them result in a HUGE AMOUNT of balloon movement? \_\_\_\_
12. Having looked again at Figs. 4.5a-4.5f and at your answers to Q7, Q9, and Q11, you might have put together that you would be INCORRECT and INCOMPLETE if you said merely that "A high pressure causes the balloon to deform" or "A low pressure causes the balloon to deform." Look once more at the six figures above and then correctly complete the statement below. HINT: You WILL have to use the word "pressure" to complete the statement.

"Air will move and the balloon will deform IF there is..."

#### 4.6 Exercise: The pressure-creating model of a battery

Consider a battery described by the exercise of Section 4.4; namely, one in which the chemical reactions inside the battery continually work to move charges internally, AWAY FROM the (-) terminal (which gives that terminal a LOW electric pressure) and TOWARD the (+) terminal (which gives that terminal a HIGH electric pressure).

Suppose such a battery is connected in a circuit with an uncharged capacitor. Before the circuit is closed, BOTH capacitor plates will have a NORMAL amount of charge, and so they will be at a NORMAL electric pressure at the instant the circuit in Figure 4.6 is closed.

1. Circle the correct answers. At the instant the circuit is closed, what is the electric pressure of the:

(+) battery terminal	HIGH	LOW	NORMAL
(-) battery terminal	HIGH	LOW	NORMAL
top capacitor plate	HIGH	LOW	NORMAL
bottom capacitor plate	HIGH	LOW	NORMAL

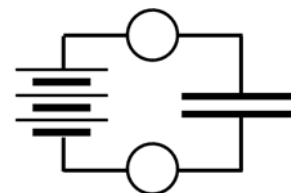

**Fig. 4.6**

first instant of connection

2. The words you circled in Q1? Write them now into Fig. 4.6, next to the parts of circuit to which they apply.

3. As you know, when the circuit is closed, the capacitor will begin to charge and the bulbs will light momentarily. According to the electric-pressure model, what makes the top bulb light up?  
HINT: Refer back to your answer to Q12 in Section 4.5.
4. According to the electric-pressure model, what makes the bottom bulb light up?
5. According to the electric-pressure model, what makes the bulbs become dim and eventually go out?  
HINT: Refer back to Section 4.3.

## **INVESTIGATION TWO: HOW CAN WE VISUALIZE PRESSURES IN A CIRCUIT?**

Here, we introduce COLORS to represent electric pressures in circuits. Color-coding circuits enables you to visualize pressure differences as the causal agents that determine when and how charge moves.

### **4.7 Color-coding for electric pressures in a circuit**

Electric pressures can be indicated on circuit diagrams by using colors to represent pressures in a circuit. We will use the color scale shown in Figure 4.7.

<b>RED</b>	<b>HIGHEST</b> electric pressure
<b>ORANGE</b>	<b>Higher-than-NORMAL</b> electric pressure
<b>YELLOW</b>	<b>NORMAL</b> electric pressure
<b>GREEN</b>	<b>Lower-than-NORMAL</b> electric pressure
<b>BLUE</b>	<b>LOWEST</b> electric pressure

**Fig. 4.7**

### **RULES FOR COLOR CODING**

1. A battery maintains the highest electric pressure at its (+) terminal and the lowest at its (-) terminal. Furthermore, any wire touching the battery terminals is IMMEDIATELY pressurized exactly like the terminal it touches. Therefore:
  - Use RED on the (+) terminal and wires directly connected to it.
  - Use BLUE on the (-) terminal and wires directly connected to it.
2. BEFORE wires and capacitor plates are connected to a battery, they all have a NORMAL amount of charge and thus a NORMAL electric pressure. Color them YELLOW.
3. Wires and capacitor plates CANNOT maintain any kind of a pressure difference. This means that the pressure MUST be the same throughout a given wire. Therefore, use ONLY ONE color for any wire, for any group of connected wires, and for any capacitor plates that these are attached to.
4. Do NOT color light bulbs. You MUST color on either side of bulbs, and often – but not always – there will be DIFFERENT colors on either side of the bulbs. Also, do NOT color the interior of a battery.



#### 4.8 Color-coding the circuit for capacitor charging

Here, you will learn to color-code circuits. Work through the line of reasoning, THEN CHECK YOUR ANSWERS WITH YOUR TEACHER BEFORE actually coloring the figures.

We start with Fig. 4.8a. The battery has NOT YET been connected.

1. From Rule #1 (see above), the (+) terminal has a \_\_\_\_\_ electric pressure and you will color it the color \_\_\_\_\_.
2. From Rule #1, the (-) terminal has a \_\_\_\_\_ electric pressure and you will color it \_\_\_\_\_.
3. From Rule #2, the electric pressure in the unconnected wires and uncharged capacitor plates is \_\_\_\_\_ pressure, and you will color them \_\_\_\_\_.
4. From Rule #4, how will you treat the bulbs?

Now, we move to Fig. 4.8b, which represents the moment of connection after the battery has been added.

5. You see that Wire A is touching the (+) terminal. From Rule #1, Wire A will have a \_\_\_\_\_ pressure, and you will color it \_\_\_\_\_.
6. Wire D is touching the (-) terminal. From Rule #1, Wire D will have a \_\_\_\_\_ pressure, and you will color it \_\_\_\_\_.

Okay, here's where you have to think a little; we're going to discuss Wires B and C, and the capacitor plates they are connected to.

7. Bulbs have (thin) filaments, which have a much higher resistance than a wire. Because of this, the IMMEDIATE change in pressure that occurred in Wire A (due to it touching the (+) terminal) does NOT happen to Wire B. Wire B is "protected," so to speak, from changing its pressure at that first instant of connection by the top bulb's filament. Thus, Wire B – at the first instant of connection – maintains the same pressure it had in Q3, which is \_\_\_\_\_ pressure. So Wire B in Fig. 4.8b is colored \_\_\_\_\_.
8. The reasoning from Q7 above applies to Wire C as well: The filament of the lower bulb "protects" Wire C from the immediate pressure change that befell Wire D after it touched the (-) terminal. Therefore, Wire C – again, at the first instant of connection – maintains the same pressure it had in Q3, which is \_\_\_\_\_ pressure; you will color Wire C in Fig. 4.8b the color \_\_\_\_\_.
9. According to Rule #3, the top capacitor plate will have a \_\_\_\_\_ pressure, and you will color it \_\_\_\_\_ in Fig. 4.8b. Similarly, according to Rule #3, the bottom capacitor plate will have a \_\_\_\_\_ pressure, and you will color it \_\_\_\_\_.

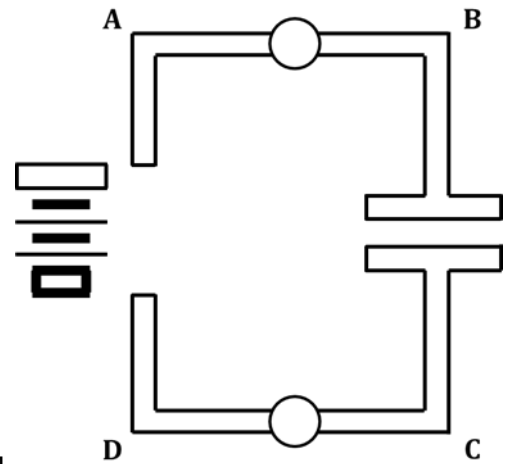

**Fig. 4.8a**  
no battery

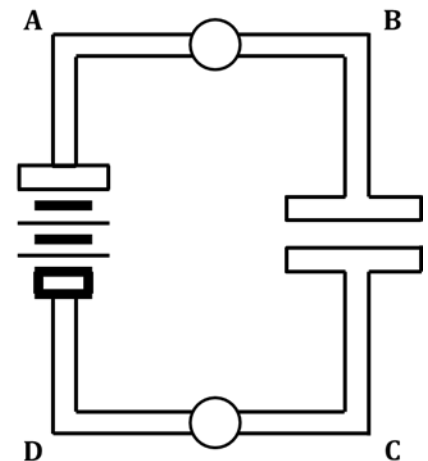

**Fig. 4.8b**  
first moment of connection;  
charging begins

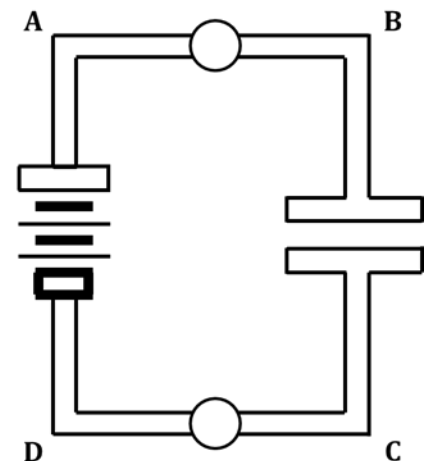

**Fig. 4.8c**  
charging continues

CHECK WITH YOUR TEACHER NOW. ONCE YOU GET THE GO-AHEAD, YOU MAY COLOR Figs. 4.8a-b.

10. In Fig. 4.8b, there is a pressure DIFFERENCE in the wires touching the top bulb. Circle the direction charge will flow through the top bulb. ← →
11. In Fig. 4.8b, there is a pressure DIFFERENCE in the wires touching the bottom bulb. Circle the direction charge will flow through the bottom bulb. ← →
12. In Fig. 4.8b, draw appropriate arrowtails and starbursts on the top and bottom bulbs to show charge flow. You need to choose the SAME number of each for both bulbs.

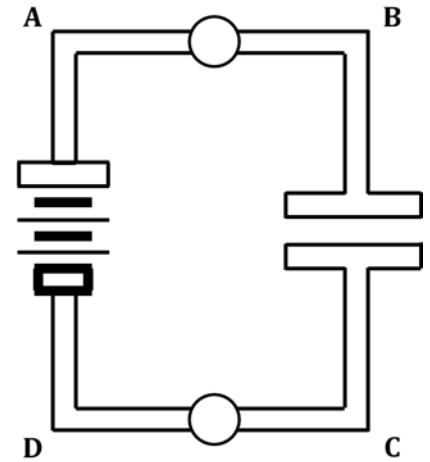

**Fig. 4.8d**  
charging completed

We now move to Fig. 4.8c, which follows on the heels of Fig. 4.8b.

13. Look at Fig. 4.8b: Is charge flowing INTO or OUT OF Wire B?
14. Thus, WHAT MUST happen to the electric pressure of Wire B? (NOTE that Wire B and the top plate are essentially a dead-end.)
15. Look at the color scale (Fig. 4.7). What is the best color for Wire B in Fig. 4.8c? It is different from Wire B's color in Fig. 4.8b.
16. In Fig. 4.8b, is charge flowing INTO or OUT OF Wire C?
17. Thus, WHAT MUST happen to the electric pressure of Wire C? (NOTE that there is only SO MUCH available charge in Wire C.)
18. Look at the color scale (Fig. 4.7). What is the best color for Wire C in Fig. 4.8c? It is different from Wire C's color in Fig. 4.8b.
19. In Fig. 4.8c, draw arrowtails and starbursts to show the amount and direction of charge flow through the top and bottom bulbs. BE CAREFUL: The NUMBER of arrowtails and starbursts will be DIFFERENT than in your answer to Q12.

Now, on to Fig. 4.8d, which – notably – is labeled “charging completed.” Keep THAT in mind.

20. Look closely, once more, at Fig. 4.8c. Based on that figure and the charge flows you drew in, decide what pressure changes THOSE WILL CAUSE in Wire B, and also in Wire C. Then look at the color scale and decide what colors best apply to the electric pressures in Wire B and also Wire C in Fig. 4.8d which, again, is labeled “charging completed.” List the colors here:

color of Wire B = \_\_\_\_\_ color of Wire C = \_\_\_\_\_

21. How do your answers to Q20 support the “charging completed” label for Fig. 4.8d? In other words, what have you observed about circuits in the past when their capacitors have been fully charged, and how do your answers to Q20 support those observations?
22. Do you need to draw arrowtails and starbursts in Fig. 4.8d?

CHECK WITH YOUR TEACHER NOW. ONCE YOU GET THE GO-AHEAD, YOU MAY COLOR Figs. 4.8c-d.

### Color-coding the circuit for capacitor discharging

We now will go through the color-coding progression for the discharge of a capacitor. We begin with Fig. 4.8e.

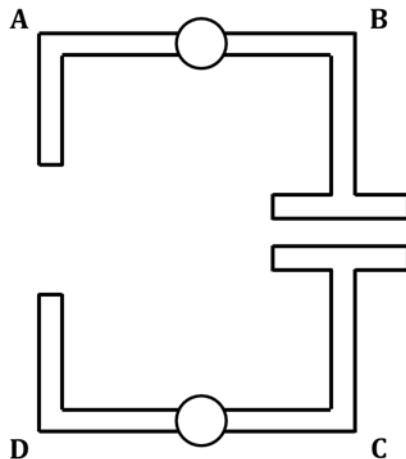

**Fig. 4.8e**  
battery removed

23. The only difference between Fig. 4.8d and 4.8e is that the battery has been removed in Fig. 4.8e. No wires have been connected, and so no charge is able to flow. State what color you would use on each wire in Fig. 4.8e.

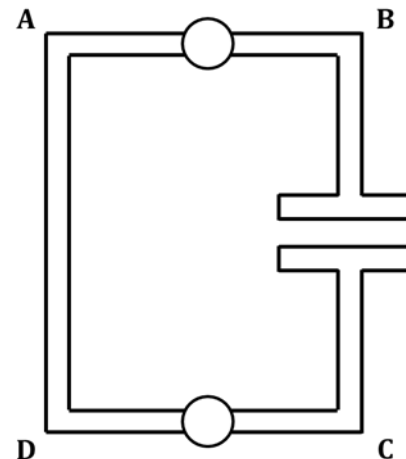

**Fig. 4.8f**  
discharging begins

24. In Fig. 4.8f, the free ends of Wires A and D have been connected. According to color-coding Rule #3, wires CANNOT maintain any pressure difference, and so MUST be represented with a single color. Look again at Wires A and D in Fig. 4.8e, and then think about WHAT ONE COLOR (i.e., WHAT ONE PRESSURE) would IMMEDIATELY result in them if you connected them together, as in Fig. 4.8f. What color is that?

25. Back in Q7 and Q8, we mentioned how the thin filaments of bulbs prevent wires from experiencing IMMEDIATE pressure changes. This phenomenon occurs here in Fig. 4.8f for Wires B and C. Therefore, what colors should these wires be, in Fig. 4.8f?

color of Wire B = \_\_\_\_\_ color of Wire C = \_\_\_\_\_

26. Draw arrowtails and starbursts on the bulbs in Fig. 4.8f, based on the pressure DIFFERENCES that exist across the bulbs. To help you determine HOW MANY arrowtails and starbursts you should use, you might want to look back at Fig. 4.8b and compare the pressure differences there with the ones present in Fig. 4.8f.

27. In Fig. 4.8g, combined-wire AD will have the SAME electric pressure that it had in Fig. 4.8f. What color is that?

Look again at the arrowtails you drew on the bulbs in Fig. 4.8f. Based on those arrowtails, answer Q28-33, which deal with Fig. 4.8g.

28. Explain WHY combined-wire AD DOESN'T change its electric pressure between Figs. 4.8f and 4.8g.

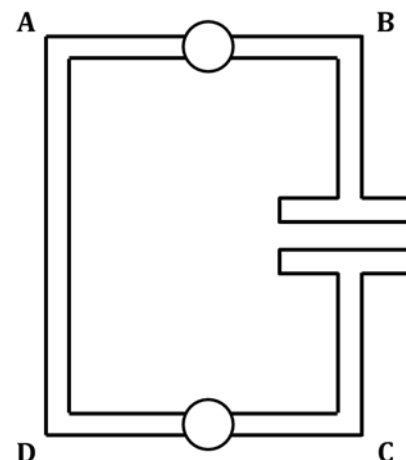

**Fig. 4.8g**  
discharging continues

29. In Fig. 4.8g, what MUST happen to the electric pressure in Wire B, and WHY?

30. What is therefore the best color choice for Wire B in Fig. 4.8g?

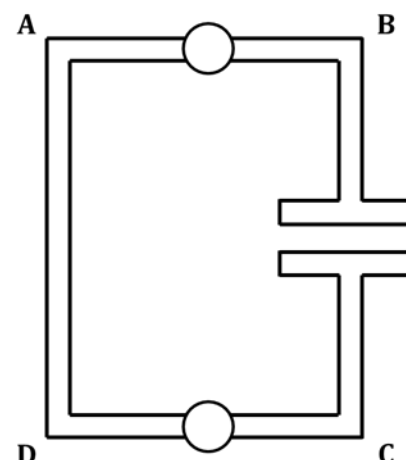

**Fig. 4.8h**  
discharging completed

31. In Fig. 4.8g, what MUST happen to the electric pressure in Wire C, and WHY?
32. What is therefore the best color choice for Wire C in Fig. 4.8g?
33. Draw arrowtails and starbursts on the bulbs in Fig. 4.8g, based on the pressure DIFFERENCES that exist across the bulbs. You might want to look back at Fig. 4.8c and compare the pressure differences there with the ones present in Fig. 4.8g.

We are nearly done!

34. Based on the arrowtails you've drawn in Fig. 4.8g and everything else that has gone before, you KNOW how to color the wires and capacitor plates in a figure labeled "discharging completed." Do it.

#### 4.9 Exercise: Using pressure difference to predict bulb brightness

Look back at Fig. 4.8b; there is a red-to-yellow pressure difference across the top bulb and a yellow-to-blue pressure difference across the bottom bulb. In the color-coding scheme (see Fig. 4.7), both of these intervals are equal to each other, in terms of AMOUNT of pressure DIFFERENCE. Red-to-yellow is, you might say, two "jumps" on the scale; yellow-to-blue is two "jumps" as well. Equal pressure differences (i.e., equal "jumps" on the scale) are WHY the top and bottom bulbs are the same brightness in Fig. 4.8b. You will note that the same essential situation exists in Fig. 4.8f; this is why you should have put the SAME starbursts on BOTH bulbs in Fig. 4.8b and BOTH bulbs in Fig. 4.8f.

A similar argument can be made for why the bulbs in Figs. 4.8c and 4.8g have the same brightness: They all have the SAME PRESSURE DIFFERENCE. Red-to-orange is the same pressure difference as green-to-blue (one "jump" on the scale). Furthermore, these bulbs are DIMMER than the ones mentioned in the previous paragraph because, for the same type of bulbs, a SMALLER pressure difference (i.e., one "jump") will drive LESS charge through the bulbs than will a BIGGER pressure difference (i.e., two "jumps"). In other words, to predict HOW BRIGHT a bulb will be, look at the wires on either side of the bulb and COUNT the NUMBER OF JUMPS APART their colors are, in Fig. 4.7.

Refer to Fig. 4.7 as you answer the following questions.

1. The LARGEST electric pressure difference would exist across a bulb if one wire touching the bulb is colored \_\_\_\_\_ and the other wire touching the bulb is colored \_\_\_\_\_.
2. If red-to-yellow is two jumps on the pressure scale, then the pressure difference mentioned in Q1 is \_\_\_\_\_ jumps.
3. The first paragraph of this exercise stated that red-to-yellow AND yellow-to-blue are both two jumps on the pressure scale. What other color combination yields the SAME pressure difference as these?
4. The second paragraph of this exercise stated that red-to-orange AND green-to-blue are both one jump on the pressure scale. What other color combinations yield the SAME pressure difference as these?

5. Rank these pressure-difference combinations across bulbs by their effect on identical types of bulbs, dimmest to brightest: blue-red green-orange yellow-green orange-blue

DIMMEST \_\_\_\_\_ < \_\_\_\_\_ < \_\_\_\_\_ < \_\_\_\_\_ BRIGHTEST

#### 4.10 Activity: Predicting and verifying bulb lighting and bulb brightness

Here are a couple of hints to help you in color-coding real circuits:

1. Start coloring red at the (+) terminal, and KEEP COLORING red until you bump into a bulb. Then “back out” with your red marker and continue coloring ALL wires that TOUCH your already-red wire, until your red lines are “boxed-in by batteries and bulbs.” Do the same thing with the blue marker, starting at the (-) battery terminal. Again, continue coloring blue until your blue lines are “boxed-in by batteries and bulbs.” You see that, as conventional charge flows through the circuit elements outside the battery, it always BEGINS that journey in a RED wire and ENDS it in a blue wire.
2. Now that you have the red and blue wires colored, you turn to any other wires. (To be clear: We are dealing here only with the case in which all bulbs are the SAME type of bulb.) The pressure-colors of these wires MUST be assigned so that the jumps TO and FROM the not-yet-colored wires are EQUAL. At this time, for a given circuit, the ONLY jumps we will be able to do are:
  - A. red-to-blue OR
  - B. red-to-yellow AND yellow-to-blue OR
  - C. red-to-orange AND orange-to-yellow AND yellow-to-green AND green-to-blue

In this activity, for each circuit given, you need to:

- (1) color-code the circuit,
- (2) predict whether each bulb will light or not,
- (3) for each lighted bulb, indicate predicted brightness using starbursts, and
- (4) build each circuit using your CASTLE kit to test your predictions.

NOTE that the conventional schematic diagrams have been modified in order to help you with the actual construction of the circuits. The black circles indicate where one or more alligator clips need to be. Also, you can see that the number of wires required to construct each circuit is shown in each figure.

Now, follow – in order – Steps (1) through (4) above. Draw appropriate starbursts on the bulbs you think will light, according to how bright you think they will be. Put an “X” through any bulb that won’t light.

Be sure you are using **LONG** bulbs when you construct these circuits!

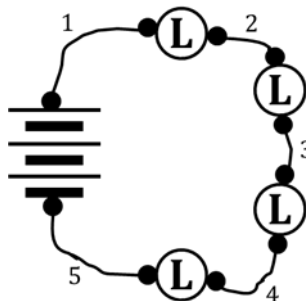

**Fig. 4.10a**  
(five wires req'd)

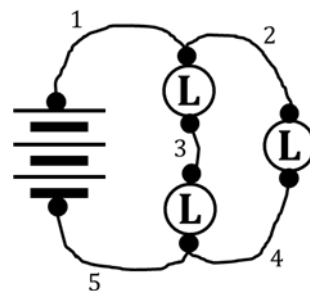

**Fig. 4.10b**  
(five wires req'd)

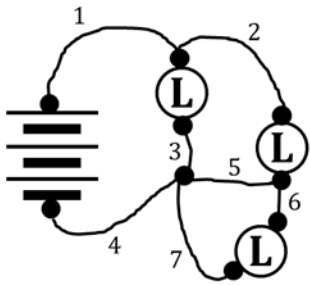

**Fig. 4.10c**  
(seven wires req'd)

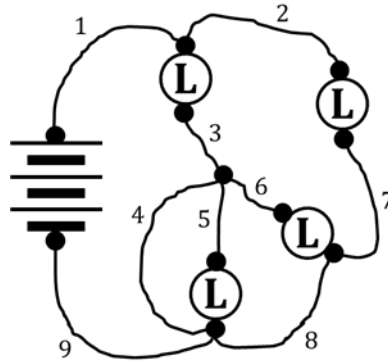

**Fig. 4.10d**  
(nine wires req'd)

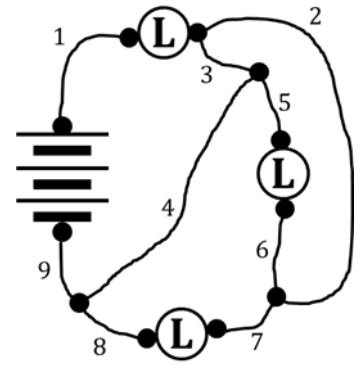

**Fig. 4.10e**  
(nine wires req'd)

**SUMMARY EXERCISE:**

1. Cite two examples of evidence that mobile charge can be compressed in electrical circuits.  
HINT: See Section 4.2.
  
2. What is meant by the term *electric pressure*? HINT: See Section 4.2.
  
3. How does a battery establish the pressure difference between the (+) and (-) terminals? See Sec. 4.4.
  
4. When color-coding, a wire is always a uniform color, and any wires it touches are also that same color.  
What is the reasoning behind this rule?
  
5. Use the term *electric pressure* to state WHY bulbs light.
  
6. In a circuit with identical bulbs, how can you use color-coding to predict the brightness of each bulb?